



Series 6209

Zetco AGA Approved
DZR Brass Ball Valve
Press-fit x MI Lockable

FEATURES

MANUFACTURED IN ITALY

FULL BORE

LOCKABLE HANDLE ALLOWS VALVE TO BE LOCKED IN OPEN OR CLOSED POSITION

AUSTRALIAN GAS ASSOCIATION APPROVAL #5301

PRESS-FIT JOINT COMPLIANT WITH AS 3688

FOR USE WITH VIEGA®, ROTHENBERGER® AND KEMPRESS® V-PROFILE TOOLS ONLY

MUST BE INSTALLED ACCORDING TO ACCOMPANYING INSTRUCTIONS & DESIGN GUIDE

CONICAL PTFE STEM SEALING SYSTEM

BLOW-OUT PROOF STEM

MUST BE OPERATED IN FULLY OPEN OR CLOSED POSITION

ALL VALVES PRESSURE TESTED DURING PRODUCTION

SIZE RANGE: 15MM TO 50MM

PRESSURE AND TEMPERATURE RATINGS

TEMPERATURE RANGE: -20°C TO 100°C

MAXIMUM OPERATING PRESSURE AT NOMINAL TEMPERATURES: 2100 kPa

ACCORDING TO AS 5601 TABLE 4.1, THE OPERATING PRESSURE OF CONSUMER GAS PIPING SYSTEMS CONTAINING COPPER TUBE IS LIMITED TO 200 kPa

FOR RATINGS AT SPECIFIC TEMPERATURES REFER TO GRAPH OVERLEAF

BIM-MED^{AUS}



AGA 5301 G
AS 4617

V.00

Series 6209

Zetco AGA Approved DZR Brass Ball Valve

Press-fit x MI Lockable

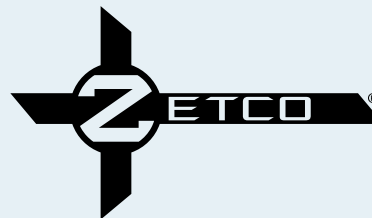

DIMENSIONAL AND COMPONENT DIAGRAM

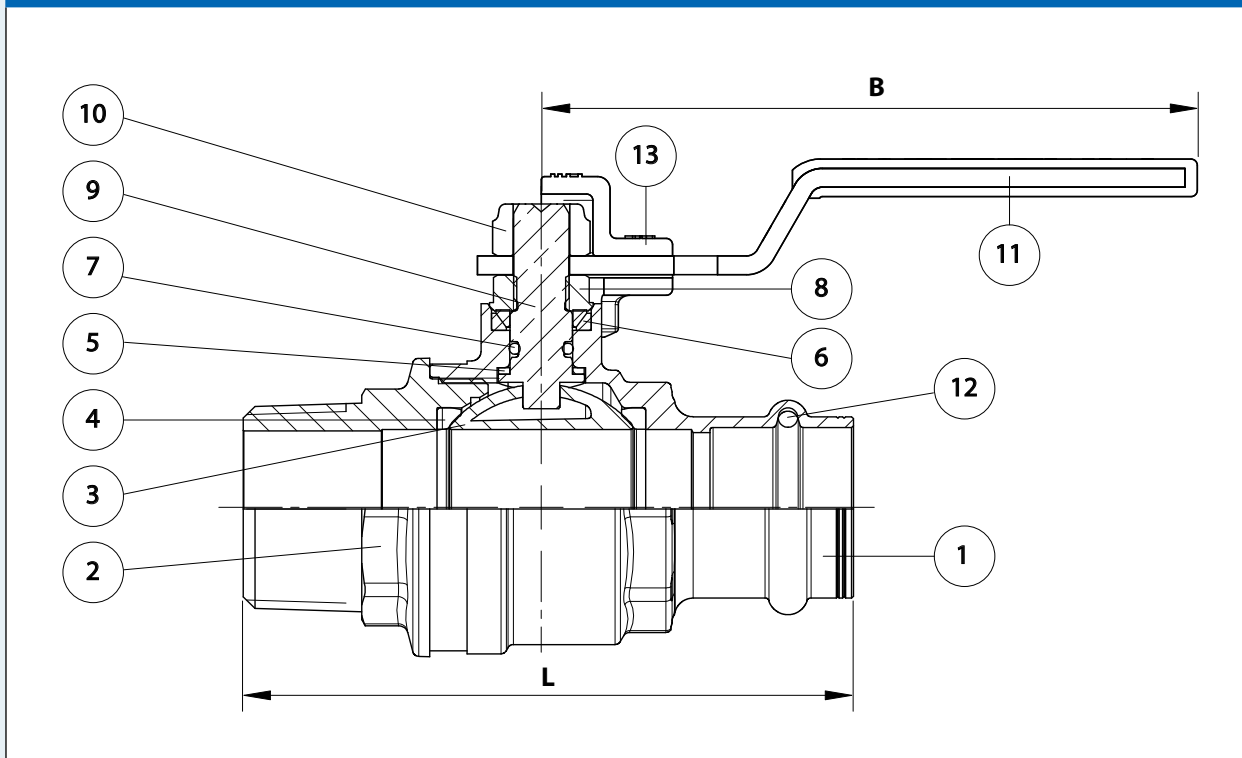

MATERIALS

POS.	PART NAME	MATERIALS
1	BODY	DZR BRASS
2	END ADAPTOR	DZR BRASS
3	BALL	DZR BRASS (CHROME PLATED)
4	SEAL	PTFE
5	THRUST WASHER	PTFE
6	CONICAL SEAL	PTFE
7	O-RING	HNBR
8	GLAND NUT	DZR BRASS
9	STEM	DZR BRASS
10	NUT	ZINC PLATED STEEL
11	HANDLE	ZINC PLATED STEEL
12	O-RING	HNBR
13	LOCKING MECHANISM	ZINC PLATED STEEL

DIMENSIONS - mm

Prod. Code	Size	A	B	L	Kv	Wgt kg
6209015	15	44	85	71	15	0.221
6209020	20	52	105	88	28	0.387
6209025	25	56	105	98	39	0.552
6209032	32	68	130	111	84	0.911
6209040	40	74	130	134	156	1.33
6209050	50	88	165	157	243	2.11

PRESSURE/TEMPERATURE DIAGRAM

